

## Features :

- Constant current mode power supply
- 100-240VAC input only
- Fully encapsulated with IP67 level
- Protections: Short circuit/Over current
- Small and compact size
- Suitable for LED lighting and sign applications
- 1 year warranty



## Specification:

MODEL		LED 700MA50W-IP67
OUTPUT	DC VOLTAGE	80V
	DC VOLTAGE RANGE	30-80V
	CURRENT RANGE	700mA $\pm$ 3%
	RATED POWER	56W
	RIPPLE & NOISE (max.)	300mVp-p
	VOLTAGE TOLERANCE	$\pm$ 3.0%
	LINE REGULATION	$\pm$ 1.0%
	LOAD REGULATION	$\pm$ 2.0%
	SETUP,RISE TIME	500ms,250ms/230VAC 500ms,250ms/115ac at full load
HOLD UP TIME(Typ.)	50ms/230VAC 24ms/115VAC at full load	
NPUT	VOLTAGE RANGE	100-240VAC
	FREQUENCY RANGE	47~63Hz
	EFFICIENCY(Typ.)	85% full load
	AC CURRENT(at full load)	1.2A/100VAC 0.6A/240VAC
	INRUSH CURRENT (max.)	COLD STAT 70A/230VAC
	LEAKAGE CURRENT	0.25mA/240VAC
PROTECT ON	OVER CURRENT	Above 105% rated output power. Protection type: Hiccup mode,recovers automatically after fault condition is removed.
	OVER TEMPERATURE	Tj 140°C typically(IC1) Detect on main control IC Protection type: Hiccup mode, recovers automatically after temperature goes down
ENVIRONMENT	WORKING TEMP.	-10~50°C
	WORKING HUMIDITY	20~90% RH non-condensing
	STORAGE TEMP., HUMIDITY	-40~80°C, 10~95% RH
	TEMP.COEFFICIENT	$\pm$ 0.03%/°C (0~50°C)
	VIBRATION	10 ~ 500Hz, 2G 10min./1cycle, period for 60min. each along X,Y, Z axes
SAFETY & EMC	SAFETY STANDARDS	Design refer to UL1310 Class 2,TUV EN60950-1, EN61347-2-13, CAN/CSA C22.2 No. 223-M91, meet IP67
	WITHSTAND VOLTAGE	I/P-O/P:3KVAC
	ISOLATION RESISTANCE	I/P-O/P:>100M Ohms / 500VDC / 25~70% RH
	EMI CONDUCTION & RADIATION	Compliance to EN55022 (CISPR22) Class B
	HARMONIC CURRENT	Compliance to EN61000-3-2,-3
EMS IMMUNITY	Compliance to EN61000-4-2,3,4,5,6,8,11; ENV50204, EN55024, light industry level, criteria A	
DIMENSION		148*40*30mm (L*W*H)

Specifications subject to change without notice

## Mechanical Specification

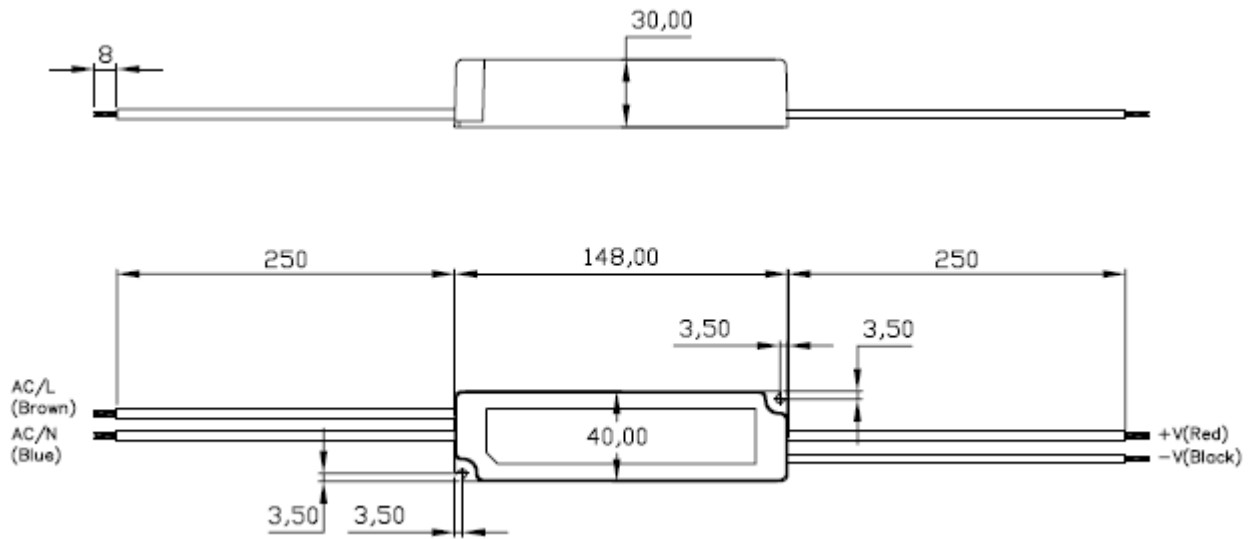

## Block Diagram

