

LED 12W-IP67-CV

12 W

Features :

- Constant voltage mode power supply
- Universal AC input / Full range
- Fully encapsulated with IP67 level
- Protections: Over current/ Over Voltage
- Small and compact size
- 100% full load burn-in test
- Suitable for LED lighting and moving sign applications
- 1 year warranty



Specification:

MODEL		LED 12V12W-IP67	LED 24V12W-IP67
OUTPUT	DC VOLTAGE	12V	24V
	RATED CURRENT	1.0A	0.5A
	CURRENT RANGE	0~1.0A	0~0.5A
	RATED POWER	12W	
	RIPPLE & NOISE (max.)	200mVp-p	
	VOLTAGE TOLERANCE	±3.0%	
	LINE REGULATION	±1.0%	
	LOAD REGULATION	±2.0%	
SETUP,RISE,HOLDUP TIME	500ms,250ms, 50ms/230VAC		
INPUT	VOLTAGE RANGE	100-240 VAC	
	FREQUENCY RANGE	47~63Hz	
	EFFICIENCY (Typ.)	77% full load	
	AC CURRENT	0.25A/100AC 0.12A/240VAC	
	INRUSH CURRENT (max.)	COLD STAT 30A/240VAC	
LEAKAGE CURRENT	0.25mA/240VAC		
PROTECTION	OVER CURRENT	Above 110% ~180%rated output power or short circuit. Protection type: Hiccup mode, recovers automaticallly	
	OVER VOLTAGE	Above 13-20V	Above 25-36V
ENVIRONMENT	WORKING TEMP.	-10~50°C	
	WORKING HUMIDITY	20~90% RH non-condensing	
	STORAGE TEMP., HUMIDITY	-40~80°C, 10~95% RH	
	TEMP.COEFFICIENT	±0.03%/°C (0~50°C)	
	VIBRATION	10 ~ 500Hz, 2G 10min./1cycle, period for 60min. each along X,Y, Z axes	
SAFETY & EMC	SAFETY STANDARDS	Design refer to UL1310 Class 2,TUV EN60950-1, EN61347-2-13, CAN/CSA C22.2 No. 223-M91, meet IP67	
	WITHSTAND VOLTAGE	I/P-O/P:3KVAC	
	ISOLATION RESISTANCE	I/P-O/P:>100M Ohms / 500VDC / 25~70% RH	
	EMI CONDUCTION&RADIATION	Compliance to EN55022 (CISPR22) Class B	
	HARMONIC CURRENT	Compliance to EN61000-3-2,-3	
EMS IMMUNITY	Compliance to EN61000-4-2,3,4,5,6,8,11; ENV50204, EN55024, light industry level, criteria A		
DIMENSION		130*25*21mm (L*W*H)	

Specifications subject to change without notice

Mechanical Specification

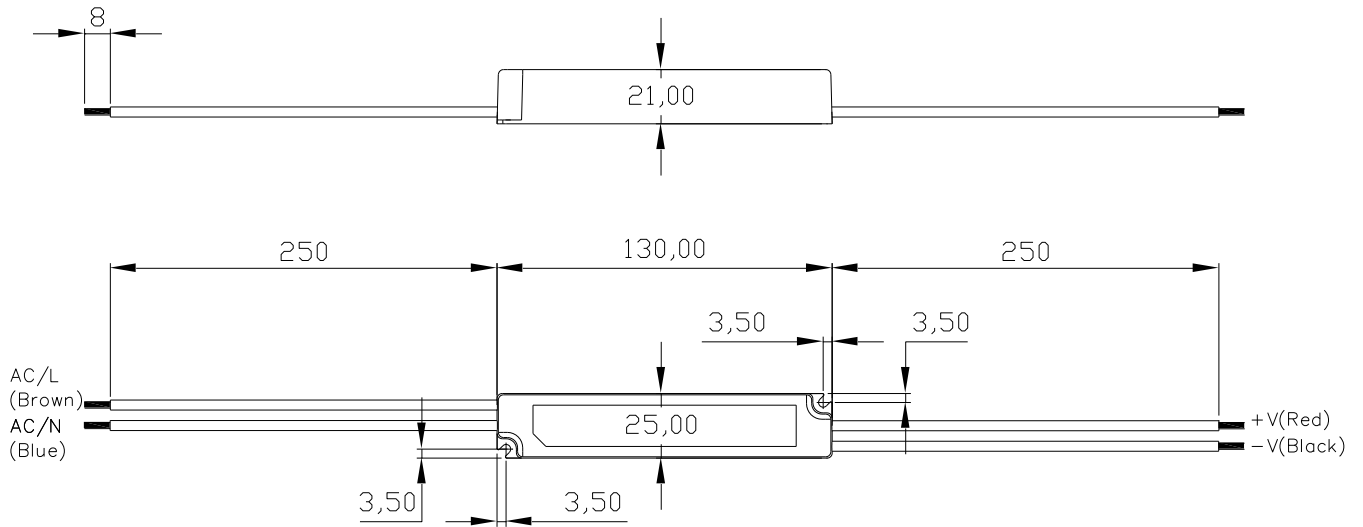

Block Diagram

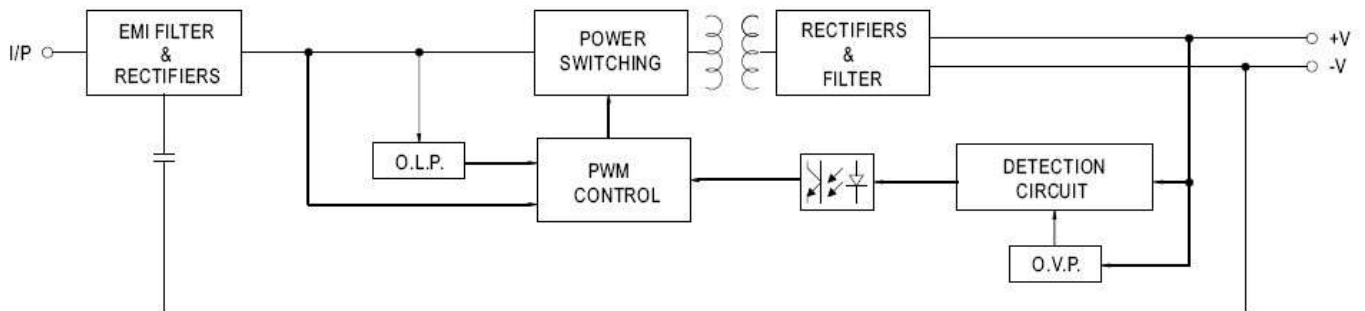

Specifications subject to change without notice